

CRM

SERIES

DESCRIPTION:

CRM Series pressure regulators provide high flow and quick, positive shut off at the desired set pressure. The regulator design is a non-balanced, spring reference, pressure reducing type regulator. They were designed especially for use as pressure build regulators for cryogenic liquid cylinders but can be used in many other applications. Solid, non-tied diaphragm provides leak-free and long-lasting performance. Optimized diaphragm and adjustment spring designs provide high flow performance. All CRM Series regulators are supplied factory pre-set and cleaned for oxygen service.

FEATURES:

- **OPTIMIZED FOR HIGH FLOW:** Design provides high flow rates at low pressure differential.
- **QUICK SHUT-OFF:** Regulators transition from the flowing condition to shut in a tight pressure band.
- **SOLID, NON-TIED, DIAPHRAGM:** Solid diaphragm eliminates potential leak path and increases sensitivity.
- **DESIGNED FOR CRYOGENICS:** All materials were selected specifically for use in cryogenic environments.
- **CLEANED FOR OXYGEN SERVICE:** Regulators are cleaned for use in Oxygen service standard.

TECHNICAL DATA:

Max Inlet Pressure: 600 PSIG (41.4 bar)

Outlet Pressure Ranges:

Spring	Outlet Pressure Range	PSI/Turn*
A	15 to 65 PSIG (1.0 to 4.5 bar)	15
B	50 to 175 PSIG (3.4 to 12.1 bar)	25
C	150 to 350 PSIG (10.3 to 24.1 bar)	55
D	300 to 525 PSIG (20.7 to 36.2 bar)	70

*PSI/Turn Value is approximate change in setpoint per full turn of the adjustment screw (CW to increase, CCW to decrease), for reference only.

Temperature Range: -320 ° to 200 °F (-196 ° to 93 °C)

Full Open Flow Coefficient: 0.51

MATERIALS OF CONSTRUCTION:

Component	Material
Body, Chamber, Valve Body, Stem, Spring Button, Spring Retainer, Bottom Plug	CDA 360 Brass, ASTM B16
Adjustment Springs	Chrome Silicon, ASTM A401
Adjustment Screw and Locknut	18-8 Stainless Steel
Valve Spring	302 SS, ASTM A313
Diaphragms	Phosphor Bronze
Diaphragm Gasket	Vulcanex ®
Valve Seal	PTFE
Chamber Seal	Gylon ®
Bottom Plug Seal	Silicone

NOTE: Regulators are assembled with Dupont Krytox® lubricant.

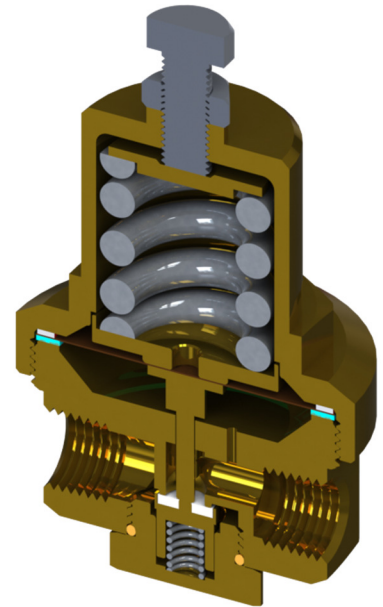

CRYOGENIC REGULATOR, MINI

DIMENSIONAL DATA

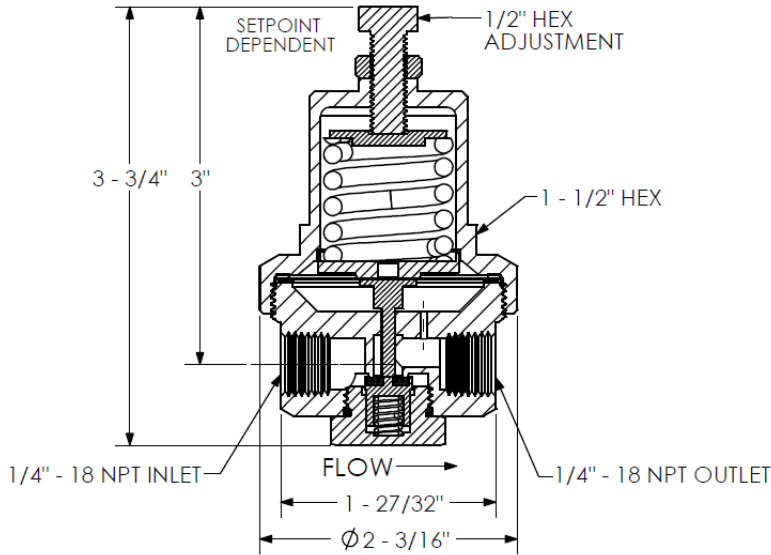

SPRING KITS / REPAIR KIT

Part Number	Spring
CRM-SK-A	A (15 to 65 PSI)
CRM-SK-B	B (50 to 175 PSI)
CRM-SK-C	C (150 to 350 PSI)
CRM-SK-D	D (300 to 525 PSI)

All Replacement Spring Kits come with a Replacement Spring, Chamber Seal, and either Diaphragm Gasket (A, B, and C springs) or Chamber Ring (D Spring).

Repair Kit P/N	Description
CRM-V-RK	Valve Only Repair Kit: Contains bottom plug o'ring, valve, and valve spring.

FLOW PERFORMANCE

QUALIFIED PERFORMANCE

High Flow Design results in Reduced Pressure Build Time and Higher Steady State Pressure during high use periods.

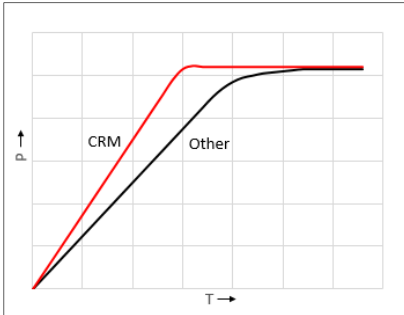

Extensively field qualified. OEM Approved & Endorsed.

SPECIFIC APPLICATIONS

For flow performance information in specific applications, consult factory. Generant has a large database of flow information for CRM Series regulators in both gas and liquid applications. Our engineers can provide flow estimates for nearly any applicable pressure condition and many different fluid medias.

Give us a call at 973-838-6500 and let us provide more information based on your specific application requirements.

HOW TO ORDER

CRM-250 - B - 125

SERIES

CRM-250 - Cryogenic Regulator Mini, 1/4" NPT, Side IN, Side OUT

SET PRESSURE

Specify set pressure in PSI
OMIT FOR STANDARD SET (BY SPRING, SEE TABLE)

SPRING RANGE

A - 15 to 65 PSI (1.0 to 4.5 bar)
B - 50 to 175 PSI (3.4 to 12.1 bar)
C - 150 to 350 PSI (10.3 to 24.1 bar)
D - 300 to 525 PSI (20.7 to 36.2 bar)

Spring	Std. Set
A	35 PSI
B	125 PSI
C	300 PSI
D	450 PSI

Standard Sets do not come engraved with "Factory Set Pressure."

PROPER COMPONENT SELECTION – When specifying a component, the total system design must be considered to ensure safe and trouble-free performance. Intended component function, materials compatibility, pressure ratings, installation, environment and maintenance are the responsibility of the system designer.



www.generant.com

1865 Route 23 South PO Box 768 Butler, New Jersey 07405 973.838.6500 Fax 973.838.4888